



APPLICATION FOR A BUILDING PERMIT

(Retaining Wall/Garden Wall Construction Details)

City of San Jacinto | 595 S. San Jacinto Ave | San Jacinto CA 92583 | 951.487.7330 | fax 951.654.9896

Date:

Must print legibly, submit (3) sets of building and plot plans. Fill out all applicable information. If any section does not apply print N/A.

Building Address:			APN:
Type of Work:			Type of Plans Submitted:
Sq. Ft. Size:	# of Stories:	# of Dwelling Units:	
Valuation:	# of Gallons:	# of BTUs:	
Building Owner:			Phone:
Address:	City:	State:	Zip:
Applicant:			Phone:
Address:	City:	State:	Zip:
Contractor:			Phone:
Address:	City:	State:	Zip:
State Lic. #	Expiration Date:		City Lic. #
Architect/Engineer/Designer:			Phone:
Address:	City:	State:	Zip:
State Lic. #	Expiration Date:		City Lic. #

OFFICE USE ONLY	Application Received:				
Planning Department Use:	1 st	2 nd	3 rd Planning Review	[<input type="checkbox"/>] Approved	[<input type="checkbox"/>] Denied
Planning Reviewed By:				Date:	
Building Department Use:	1 st	2 nd	3 rd Building Review	[<input type="checkbox"/>] Approved	[<input type="checkbox"/>] Denied
Building Reviewed By:				Date:	
Comments:					

TYPE 1: 6" TOE

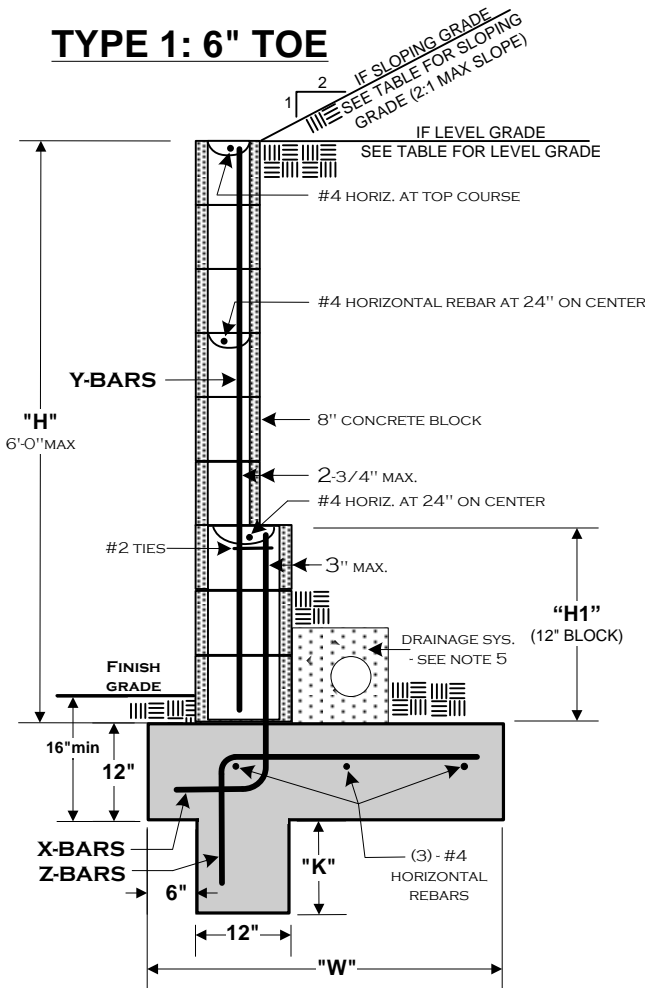

TYPE 2: 6" HEEL

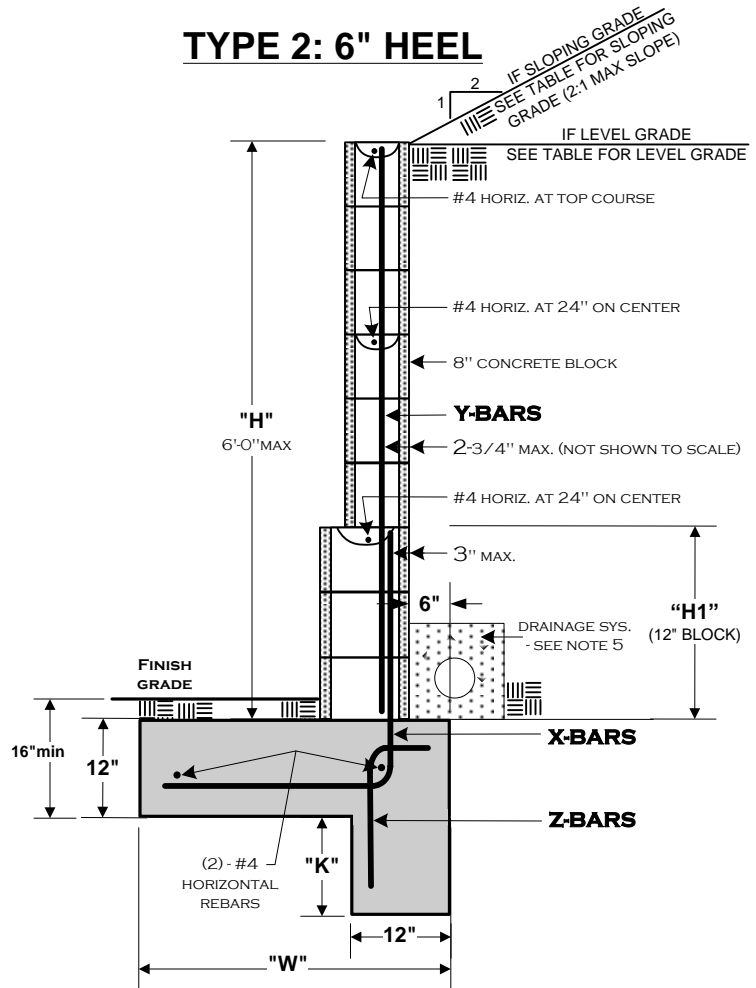

TYPE 1: 6" TOE							
GRADE CONDITION	"H" (WALL HEIGHT)	"H1" (12" BLOCK)	"W" (FOOTING WIDTH)	X BARS	Y BARS	ZBARS	"K" (KEY DEPTH)
SLOPING GRADE AT TOP OF WALL (2:1 MAX)	5'-1" to 6'-0"	24"	69"	#4 @ 16"	#4 @ 32"	#4 @ 11"	30"
	4'-1" to 5'-0"	N/R	48"	#4 @ 16"	#4 @ 16"	#4 @ 12"	25"
	3'-1" to 4'-0"	N/R	30"	#4 @ 32"	#4 @ 32"	#4 @ 32"	16"
	Up to 3'-0"	N/R	18"	#4 @ 32"	#4 @ 32"	#4 @ 32"	8"
LEVEL GRADE AT TOP OF WALL	5'-1" to 6'-0"	24"	45"	#4 @ 24"	#4 @ 32"	#4 @ 24"	8"
	4'-1" to 5'-0"	N/R	36"	#4 @ 24"	#4 @ 24"	#4 @ 24"	7"
	3'-1" to 4'-0"	N/R	24"	#4 @ 32"	#4 @ 32"	#4 @ 32"	5"
	Up to 3'-0"	N/R	21"	#4 @ 32"	#4 @ 32"	#4 @ 32"	N/R

TYPE 2: 6" HEEL							
GRADE CONDITION	"H" (WALL HEIGHT)	"H1" (12" BLOCK)	"W" (FOOTING WIDTH)	X BARS	Y BARS	ZBARS	"K" (KEY DEPTH)
SLOPING GRADE AT TOP OF WALL (2:1 MAX)	5'-1" to 6'-0"	24"	39"	#4 @ 16"	#4 @ 32"	#4 @ 12"	28"
	4'-1" to 5'-0"	N/R	29"	#4 @ 16"	#4 @ 16"	#4 @ 12"	22"
	3'-1" to 4'-0"	N/R	24"	#4 @ 32"	#4 @ 32"	#4 @ 32"	15"
	Up to 3'-0"	N/R	18"	#4 @ 32"	#4 @ 32"	#4 @ 32"	8"
LEVEL GRADE AT TOP OF WALL	5'-1" to 6'-0"	24"	33"	#4 @ 24"	#4 @ 32"	#4 @ 24"	18"
	4'-1" to 5'-0"	N/R	26"	#4 @ 24"	#4 @ 24"	#4 @ 24"	13"
	3'-1" to 4'-0"	N/R	20"	#4 @ 32"	#4 @ 32"	#4 @ 32"	7"
	Up to 3'-0"	N/R	20"	#4 @ 32"	#4 @ 32"	#4 @ 32"	N/R

N/R = NOT REQUIRED

SEE PAGE 2 FOR ADDITIONAL INFORMATION

DISCLAIMER:

ALTERNATE RETAINING WALL DESIGNS MAY BE POSSIBLE WHEN PROVIDED WITH AN ENGINEERED ANALYSIS. USE OF THIS STANDARD DESIGN IS AT THE USER'S RISK AND CARRIES NO IMPLIED OR INFERRED GUARANTEE AGAINST FAILURE OR DEFECTS.

WESTERN RIVERSIDE COUNTY CODE UNIFORMITY PROGRAM			
CITY OF SAN JACINTO			
BUILDING DEPARTMENT			
RETAINING WALLS			
		595 S. SAN JACINTO AVENUE SAN JACINTO, CA 92583	
PHONE 951-487-7330		595 S. SAN JACINTO AVENUE SAN JACINTO, CA 92583	
FAX 951-654-9896	01/01/2008	RETWALLFINALVSD	PAGE 1 OF 2

GENERAL NOTES:

- 1) ALL WORK SHALL CONFORM TO THE ADOPTED CODES AND ZONING REGULATIONS.
- 2) CONCRETE BLOCK MASONRY SHALL COMPLY WITH THE FOLLOWING:
 - A. CONCRETE MASONRY SHALL CONFORM TO ASTM C-90, GRADE - N.
 - B. MORTAR: TYPE M OR S.
 - C. GROUT ALL CELLS W/2000 PSI PORTLAND CEMENT GROUT.
- 3) THE ULTIMATE COMPRESSIVE STRENGTH REQUIRED FOR FOUNDATION CONCRETE SHALL BE 2500 PSI.
- 4) ALL REINFORCING STEEL SHALL BE INTERMEDIATE GRADE ASTM A615-40 AND OVERLAP SPLICES SHALL BE 40 BAR DIAMETERS MINIMUM. ALL REBAR HOOKS SHALL BE A MINIMUM OF 12 TIMES THE REBAR DIAMETER (12bd) IN LENGTH.
- 5) PROVIDE RETAINING WALL DRAINAGE SYSTEM AS FOLLOWS:
 PROVIDE 1CF/FT OF CLEAN COARSE GRAVEL WITH 4" DIAMETER PERFORATED PVC DRAINAGE PIPE WITH 1% GRADIENT TO DRAIN - OR OMIT HEAD JOINTS IN FIRST COURSE.
- 6) OPTIONAL: INSTALLATION OF A MOISTURE BARRIER ON THE FILL SIDE OF THE WALL WILL HELP TO PREVENT MOISTURE FROM PENETRATING THE VISIBLE SIDE OF THE WALL, RESULTING IN DISCOLORATION.
- 7) THIS RETAINING WALL STANDARD IS **NOT** DESIGNED TO SUPPORT SURCHARGE LOADS FROM MOTOR VEHICLES OR OTHER STRUCTURES.
- 8) CLEANOUTS SHALL BE PROVIDED FOR ALL GROUT POURS OVER 5 FEET IN HEIGHT. WHERE REQUIRED, CLEANOUTS SHALL BE PROVIDED IN THE BOTTOM COURSE AT EVERY VERTICAL BAR AND SHALL BE SEALED AFTER INSPECTION AND BEFORE GROUTING.

REQUIRED INSPECTIONS:

- 1) FOOTING:
 EXCAVATION TRENCH CLEAN WITH STEEL IN PLACE AND SUPPORTED 3" ABOVE AND AWAY FROM THE SURROUNDING EARTH/DIRT.
- 2) REBAR/PRE-GROUT AND DRAINAGE SYSTEM:
 BOND BEAM REBAR AND VERTICAL REBAR IN PLACE - INSPECTION PRIOR TO PLACING GROUT.
 DRAINAGE SYSTEM COMPLETE.
- 3) FINAL:
 AFTER GROUT IS PLACED AND BACKFILL COMPLETED - PRIOR TO ANY DECORATIVE CAP PLACEMENT.

SETBACK FROM TOP OF SLOPE:

ALL FOOTINGS ADJACENT TO SLOPES TO BE AT LEAST 5' TO DAYLIGHT AS SHOWN BELOW.

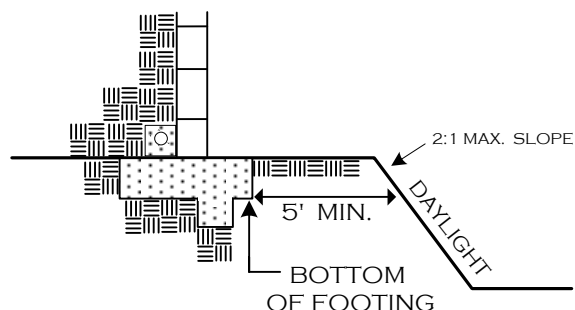

DESIGN PARAMETERS:

ACTIVE SOIL PRESSURE (PSF)	
LEVEL BACKFILL	= 30
SLOPING (2:1 MAX)	= 43
PASSIVE SOIL BEARING (PSF)	= 150
COEFFICIENT OF FRICTION	= 0.25
ALLOWABLE SOIL BEARING PRESSURE (PSF)	= 1500
(NO INCREASES TAKEN FOR DEPTH OR WIDTH OF FOOTING)	

DISCLAIMER:

ALTERNATE RETAINING WALL DESIGNS MAY BE POSSIBLE WHEN PROVIDED WITH AN ENGINEERED ANALYSIS. USE OF THIS STANDARD DESIGN IS AT THE USER'S RISK AND CARRIES NO IMPLIED OR INFERRED GUARANTEE AGAINST FAILURE OR DEFECTS.

WESTERN RIVERSIDE COUNTY CODE UNIFORMITY PROGRAM			
	CITY OF SAN JACINTO		
	BUILDING DEPARTMENT		
RETAINING WALLS			
PHONE 951-487-7330		595 S. SAN JACINTO AVENUE SAN JACINTO, CA 92583	
FAX 951-654-9896	01/01/2008	RETWALLFINAL.VSD	PAGE 2 OF 2

FOOTING OPTION "A"

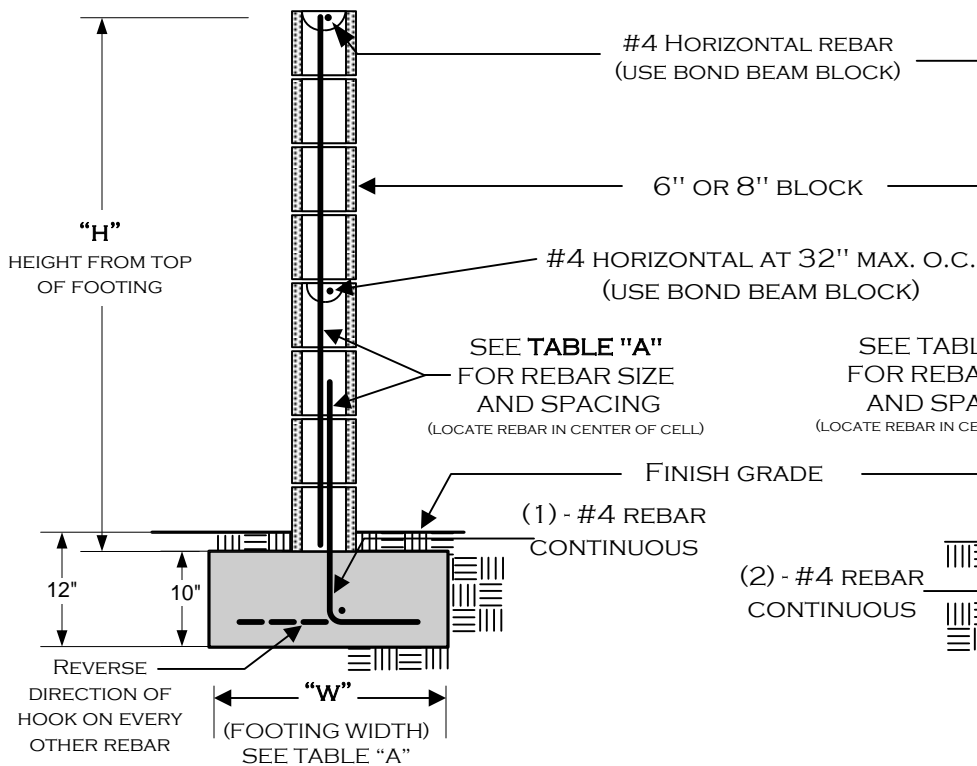

"H"	"W"	VERTICAL REINFORCEMENT
3'	17"	#4 @ 48" O.C.
4'	20"	#4 @ 48" O.C.
5'	23"	#4 @ 48" O.C.
6'	29"	#4 @ 24" O.C.

ALL FOOTINGS ADJACENT TO SLOPES TO BE AT LEAST 5' TO DAYLIGHT AS SHOWN BELOW.

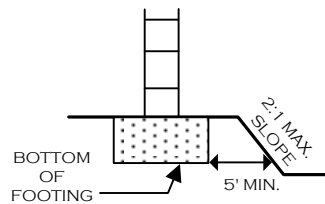

FOOTING OPTION "B"

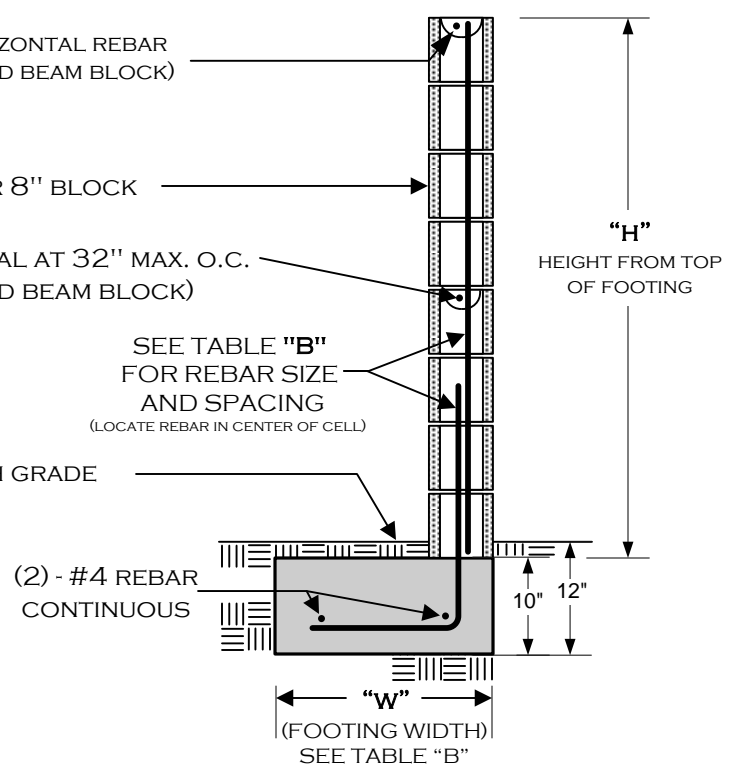

"H"	"W"	VERTICAL REINFORCEMENT
3'	19"	#4 @ 48" O.C.
4'	22"	#4 @ 48" O.C.
5'	29"	#4 @ 48" O.C.
6'	34"	#4 @ 24" O.C.

NOTES:

- 1) THIS DESIGN DOES **NOT** ALLOW GRADE DIFFERENTIALS OF MORE THAN 6" ON OPPOSING SIDES OF THE WALL. THIS IS **NOT** A RETAINING WALL.
- 2) FENCE HEIGHTS ARE REGULATED — CONSULT ZONING REGULATIONS BEFORE BEGINNING CONSTRUCTION.
- 3) NO WATER COURSE OR NATURAL DRAINAGE SHALL BE OBSTRUCTED.
- 4) GROUT **ONLY** THE CELLS CONTAINING REBAR. THIS WALL IS **NOT** DESIGNED FOR ALL CELLS TO BE GROUTED.
- 5) ALL REBAR TO BE ASTM SPEC. A615, GRADE 40 MINIMUM.
- 6) ALL REBAR LAP SPLICES TO BE 24" MINIMUM.
- 7) ALL MASONRY UNITS TO BE ASTM C-90 GRADE N.
- 8) REBAR TO BE CENTERED IN MASONRY CELLS.

SEE PAGE 2 FOR ADDITIONAL INFORMATION

DISCLAIMER:

ALTERNATE DESIGNS MAY BE POSSIBLE WHEN PROVIDED WITH AN ENGINEERED ANALYSIS. USE OF THIS STANDARD DESIGN IS AT THE USER'S RISK AND CARRIES NO IMPLIED OR INFERRED GUARANTEE AGAINST FAILURE OR DEFECTS.

CHECK WITH THE BUILDING DEPARTMENT TO VERIFY IF A BUILDING PERMIT IS REQUIRED.

WHEN A PERMIT IS REQUIRED, THE FOLLOWING INSPECTIONS ARE REQUIRED:

- 1) **FOOTING**; EXCAVATION TRENCH CLEAN WITH STEEL IN PLACE AND SUPPORTED 3" ABOVE AND AWAY FROM THE SURROUNDING EARTH/DIRT.
- 2) **REBAR/PRE-GROUT**; BOND BEAM REBAR AND VERTICAL REBAR IN PLACE - INSPECTION PRIOR TO PLACING GROUT.
- 3) **FINAL**; AFTER GROUT IS PLACED - PRIOR TO ANY DECORATIVE CAP PLACEMENT.

WESTERN RIVERSIDE COUNTY CODE UNIFORMITY PROGRAM



CITY OF SAN JACINTO BUILDING DEPARTMENT

FREESTANDING BLOCK WALL

PHONE 951-487-7330

595 S. SAN JACINTO AVENUE
SAN JACINTO, CA 92583

FAX 951-654-9896

1/1/2008

GARDENWALLFINAL2008.VSD

PAGE 1 OF 2

REBAR PLACEMENT ILLUSTRATION

FOOTING OPTION B

(TYPICAL)
ALL REBAR SPLICES
24" MIN. OVERLAP

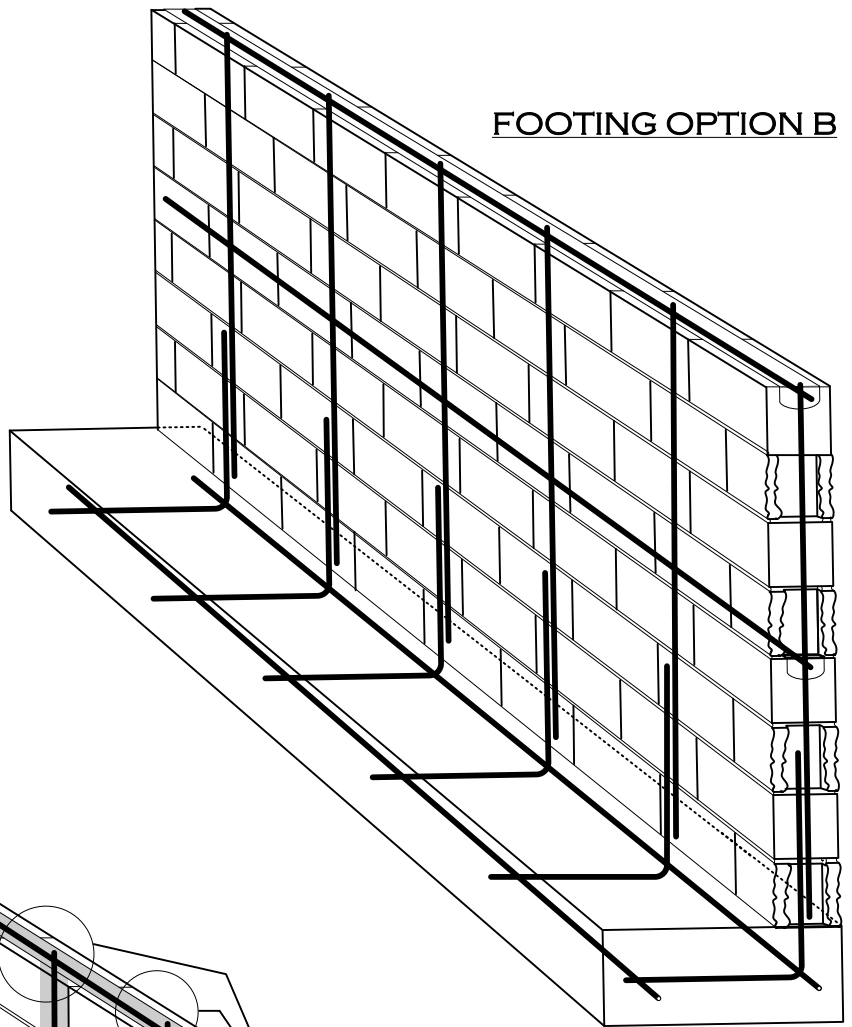

(TYPICAL)
ONLY CELLS AND BOND BEAM
COURSES WITH REBAR TO BE
GROUTED
(DO NOT SOLID GROUT ENTIRE WALL - USE
GROUT STOP MESH AS APPROPRIATE)

FOOTING OPTION A

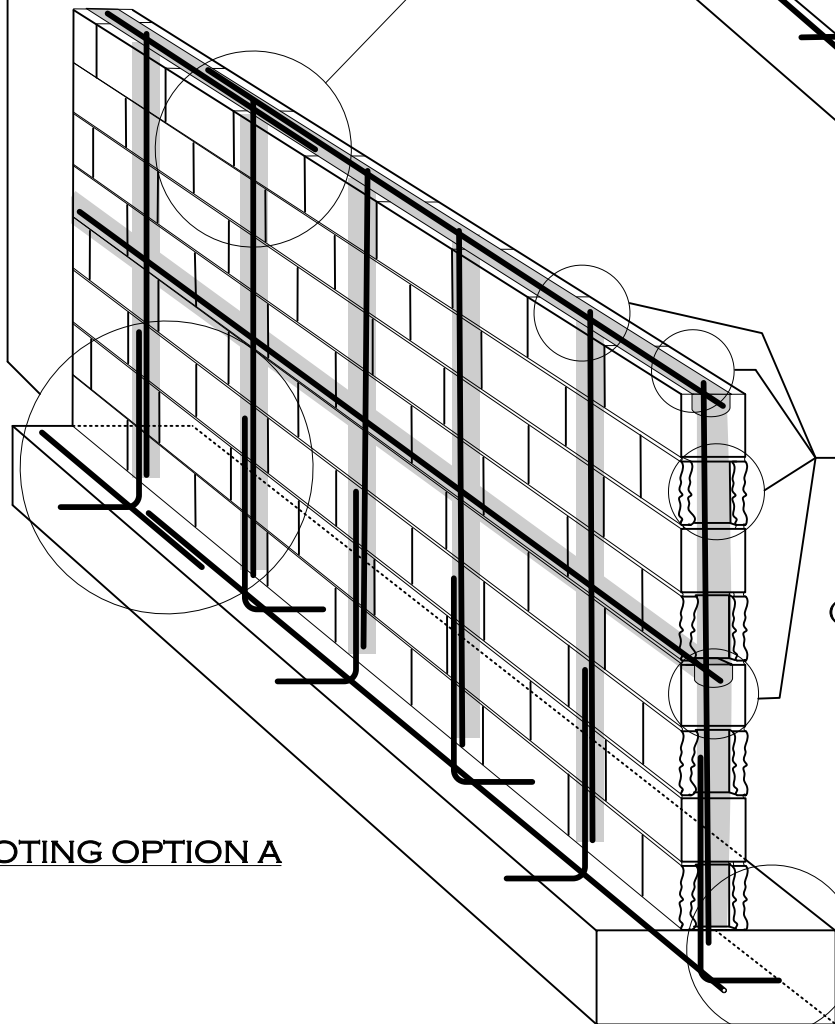

(TYPICAL)
ALL REBAR SHALL HAVE A
MINIMUM OF 3" CONCRETE
COVER AT FOOTINGS

DESIGN PARAMETERS:

ACTIVE SOIL PRESSURE (PSF) = 30
 PASSIVE SOIL BEARING (PSF) = 150
 COEFFICIENT OF FRICTION = 0.25
 ALLOWABLE SOIL BEARING (PSF) = 1500
 WIND = 85 MPH, EXPOSURE C
 SEISMIC DESIGN CATEGORY 'E', SITE CLASS 'D'



WESTERN RIVERSIDE COUNTY CODE UNIFORMITY PROGRAM



CITY OF SAN JACINTO
BUILDING DEPARTMENT

FREESTANDING BLOCK WALL

PHONE 951-487-7330

595 S. SAN JACINTO AVENUE
SAN JACINTO, CA 92583

FAX 951-654-9896

1/1/2008

GARDENWALLFINAL2008.VSD

PAGE 2 OF 2

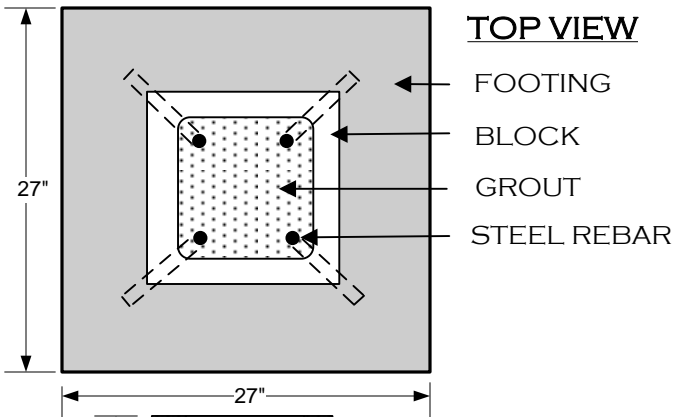

TOP VIEW

FOOTING
BLOCK
GROUT
STEEL REBAR

**REBAR
PLACEMENT
ILLUSTRATION**

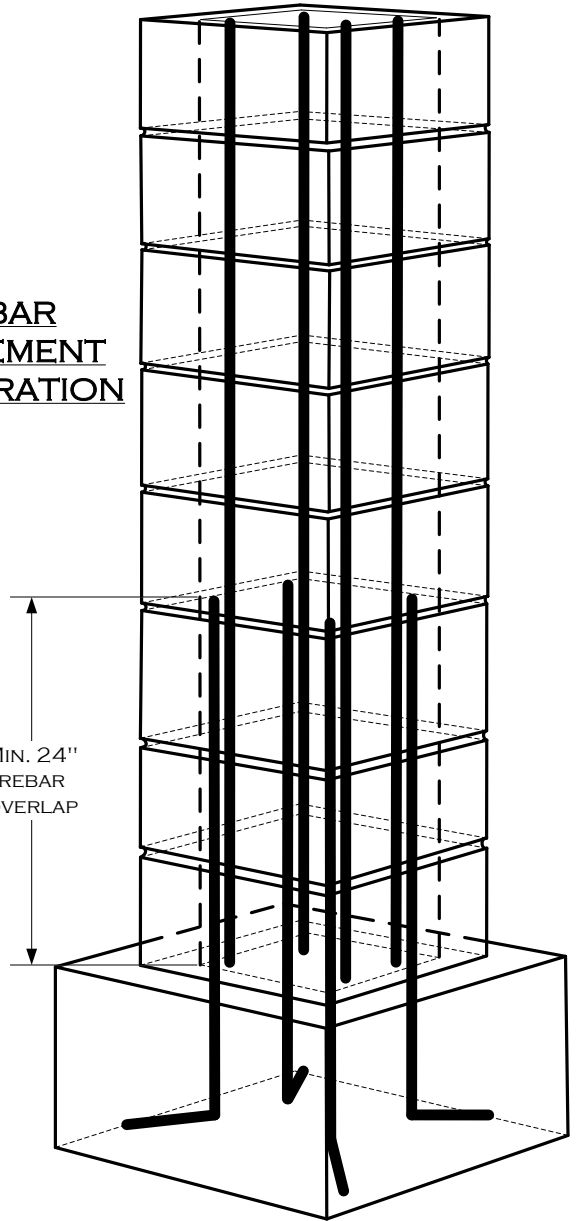

SECTION VIEW

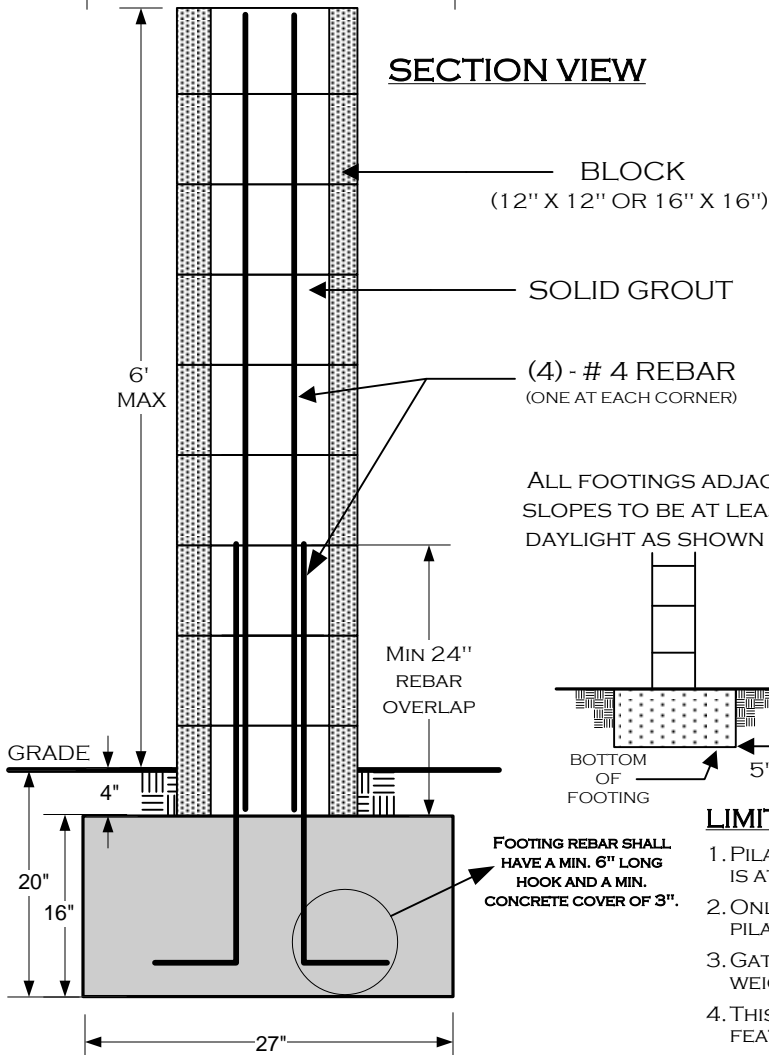

ALL FOOTINGS ADJACENT TO SLOPES TO BE AT LEAST 5' TO DAYLIGHT AS SHOWN BELOW.

FOOTING REBAR SHALL HAVE A MIN. 6" LONG HOOK AND A MIN. CONCRETE COVER OF 3".

LIMITATIONS:

1. PILASTER SPACING SHALL NOT EXCEED 20 FT. WHEN OTHER INFILL FENCING IS ATTACHED.
2. ONLY OPEN TYPE FENCING (SUCH AS WROUGHT IRON) MAY BE ATTACHED TO PILASTERS. SOLID TYPE FENCING MAY **NOT** BE ATTACHED TO PILASTER.
3. GATES AND DOORS ATTACHED TO PILASTER ARE LIMITED TO 200# MAX. WEIGHT AND 4 FT. MAX. WIDTH PER PILASTER.
4. THIS PILASTER DESIGN IS INTENDED TO BE USED **ONLY** AS A FENCING FEATURE AND IS NOT INTENDED TO SUPPORT ANY OTHER LOADS .
5. FENCE HEIGHTS ARE REGULATED – CONSULT ZONING REGULATIONS BEFORE BEGINNING CONSTRUCTION.
6. INSTALLATION OF ELECTRIC CIRCUITS, CONDUITS, OR LIGHTING FIXTURES REQUIRE ELECTRICAL PERMITS AND INSPECTION.
7. FOOTINGS TO BE PLACED IN UNDISTURBED SOIL OR PROPERLY COMPACTED AND ENGINEERED FILL.
8. FOR DESIGN PARAMETERS, SEE FREESTANDING BLOCK WALL STANDARD.

CHECK WITH THE BUILDING DEPARTMENT TO VERIFY IF A BUILDING PERMIT IS REQUIRED.

WHEN A BUILDING PERMIT IS REQUIRED, THE FOLLOWING INSPECTIONS ARE ALSO REQUIRED:

- 1) **FOOTING**; EXCAVATION TRENCH CLEAN WITH STEEL IN PLACE AND SUPPORTED 3" ABOVE AND AWAY FROM THE SURROUNDING THE EARTH/DIRT.
- 2) **REBAR/PRE-GROUT**; VERTICAL REBAR IN PLACE - INSPECTION PRIOR TO PLACING GROUT.
- 3) **FINAL**; AFTER GROUT IS PLACED - PRIOR TO ANY DECORATIVE CAP PLACEMENT.

DISCLAIMER:

ALTERNATE DESIGNS MAY BE POSSIBLE WHEN PROVIDED WITH AN ENGINEERED ANALYSIS. USE OF THIS STANDARD DESIGN IS AT THE USER'S RISK AND CARRIES NO IMPLIED OR INFERRED GUARANTEE AGAINST FAILURE OR DEFECTS.

WESTERN RIVERSIDE COUNTY CODE UNIFORMITY PROGRAM



**CITY OF SAN JACINTO
BUILDING DEPARTMENT**

MASONRY PILASTER

PHONE 951-487-7330

595 S. SAN JACINTO AVENUE
SAN JACINTO, CA 92583

FAX 951-654-9896

1/1/2008

PILASTERFINAL2008.VSD

PAGE 1 OF 1



PERMIT NO. _____

PLOT PLAN

NAME: _____ PHONE: _____

SITE ADDRESS: _____

ASSESSOR'S PARCEL NUMBER: _____

	REAR PROPERTY LINE	
SIDE PROPERTY LINE		SIDE PROPERTY LINE
	FRONT PROPERTY LINE	

PLEASE PROVIDE NORTH ARROW